

VENTOLE IN NYLON

NYLON FANS

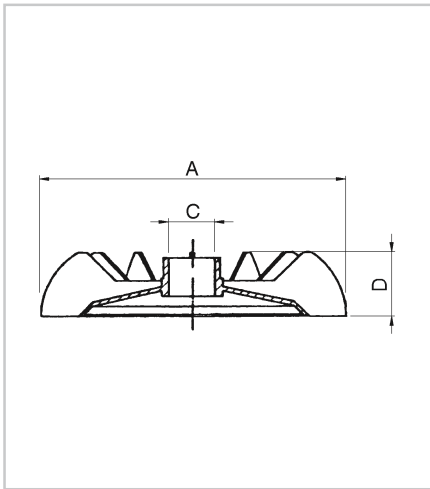

Articolo Art.	A	Ø C	D
DM.52	87	8	20
DM.56	100	11	20
DM.63	117	14	23
DM.71	134	14	29
DM.80	144	19	29
DM.90	167	24	32
DM.100	183	28	34
DM.112	205	28	37
DM.132.38	239	38	49
DM.132.40	239	40	49
DM.160	294	45	54
DM.180	339	50	60

Con morsetto a collare. Materiale in nylon termoidurente. Resistenza al calore 120°C.
Complete with clamp. Thermosetting nylon material. Heat resistance 120°C.

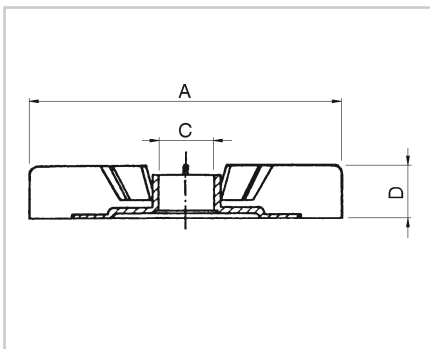

Articolo Art.	A	Ø C	D
VA.63	95	14	14
VA.71	126	14	20
VA.80	142	19	25
VA.90	161	24	29
VA.100	173	28	30
VA.112	194	28	33
VA.132.38	230	38	39
VA.132.40	230	40	39

Ventola piatta. Con morsetto a collare. / Flat fan. Complete with clamp.

COPRIVENTOLE IN MATERIALE TERMOPLASTICO

FAN COVERS IN THERMOPLASTIC MATERIAL

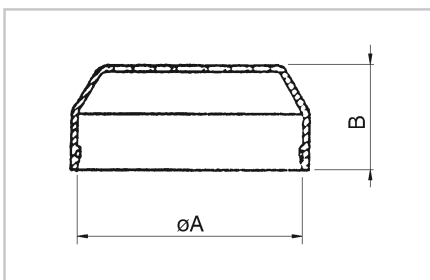

Articolo Art.	A	B
MEC.56	108	47
MEC.63	122	50
MEC.71	137	54
MEC.80	156	57
MEC.90	173	61
MEC.100	193	70

Resistenza al calore 130° C. / Heat resistance 130°C.