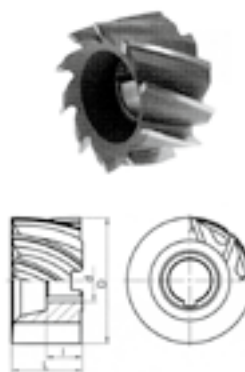
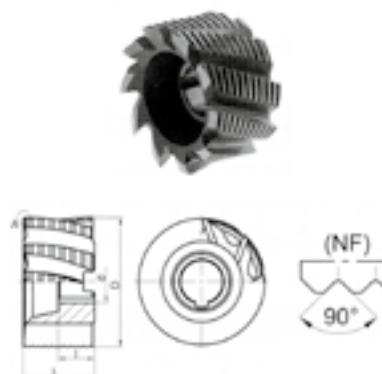

**Art. 111 - Hss Denti**
*Elica 45° elicoidali esecuzione n - Taglio Destro*

D mm	Spessore L - mm	Foro d - mm	Denti	€
40	32	16	8	50,00
50	36	22	8	59,00
63	40	27	8	80,00
80	45	27	10	140,00
100	50	32	10	200,00

**FRESE CIL. FRONT. CON ROMPITRUCIOLO A SGROSSARE**  
**SHELL MILLS WITH CHIPBREAKER**
**Art. 112 HSS**
*Denti Elicoidali - Taglio Destro*

D mm	Spessore L - mm	Foro d - mm	Denti	€
40	32	16	6	85,00
50	36	22	8	92,00
63	40	27	8	130,00
80	45	27	10	220,00
100	50	32	10	290,00

**FRESE FRONTALI CODOLO CONICO HSS**  
**MORSE TAPER SHANK END MILL**
**Art. 110 - Foro Filettato**
*Serie Corta - Tagli Elicoidali*

Ø m/m	L. Tagliente m/m	L. Totale m/m	Cono Morse N.	€
10	28	100	1	17,00
12	32	105	1	20,00
14	32	105	1	21,00
15	36	115	2	25,00
16	36	115	2	26,00
18	40	120	2	29,00
20	45	125	2	48,00
22	45	125	2	49,00
24	50	150	3	49,00
25	50	150	3	58,00
26	56	155	3	58,00
28	56	155	3	58,00
30	65	165	3	75,00
32	65	165	3	75,00
34	70	195	4	75,00
36	70	195	4	76,00
38	70	195	4	85,00
40	70	195	4	130,00

