

Diametro albero (mm) Shaft diameter (mm)	Sigla Designation				Dimensioni (mm) Dimensions (mm)			Coefficienti di carico (N) Basic Load Ratings (N)		Velocità limite Limiting Speed
	Astucci a rullini aperti Open end	Peso (g) Weight (g)	Astucci a rullini con fondello Closed end	Peso (g) Weight (g)	F _w	D	C	Dinamico C Dynamic C	Statico C ₀ Static C ₀	Olio (N. giri max) Oil (max rpm)
3	HK 0306 TN	1	BK 0306 TN	1	3	6.5	6	1 170	800	43 700
4	HK 0408 TN	1.6	BK 0408TN	1.8	4	8	8	1 690	1 240	39 000
5	HK 0509	2	BK 0509	2.1	5	9	9	2 280	1 890	36 000
6	HK 0606	1.8	-	-	6	10	6	2 100	1 700	34 500
	HK 0608	2.1	BK 0608	2.2	6	10	8	1 900	1 570	33 200
	HK 0609	2.2	BK 0609	2.6	6	10	9	2 700	2 470	33 200
7	HK 0709	2.3	BK 0709	2.9	7	11	9	2 950	2 800	29 400
8	HK 0808	2.7	BK 0808	3	8	12	8	2 600	2 470	26 600
	HK 0810	3	BK 0810	3.4	8	12	10	3 600	3 750	26 600
9	HK 0908	3	BK 0908	3.4	9	13	8	3 370	3 560	23 700
	HK 0910	4	BK 0910	4.3	9	13	10	4 050	4 400	23 700
	HK 0912	4.6	BK 0912	4.9	9	13	12	5 040	6 000	23 700
10	HK 1010	4.1	BK 1010	4.3	10	14	10	4 180	4 850	21 850
	HK 1012	4.8	BK 1012	5	10	14	12	5 200	6 450	21 850
	HK 1015	6	BK 1015	6.2	10	14	15	6 450	8 350	21 850
12	HK 1210	4.6	BK 1210	5.2	12	16	10	4 700	5 900	19 000
	HK 1212	9	BK 1212	10	12	18	12	6 150	6 900	18 000
13	HK 1311	8.5	-	-	13	19	11	6 300	6 300	14 000
	HK 1312	8.9	BK 1312	11.2	13	19	12	6 450	7 500	17 000
14	HK 1412	10.5	BK 1412	12	14	20	12	6 800	8 000	15 200
15	HK 1512	11.1	BK 1512	12.7	15	21	12	7 500	8 950	15 200
	HK 1516	15	BK 1516	16.5	15	21	16	9 950	13 700	15 200
	HK 1522 - ZW	20.4	BK 1522	22	15	21	22	12 700	18 500	15 200
16	HK 1612	11.7	BK 1612	13.8	16	22	12	7 200	9 200	14 200
	HK 1616	15.8	BK 1616	17.6	16	22	16	10 300	14 500	14 200
	HK 1622 - ZW	21.7	BK 1622	23.4	16	22	22	12 450	18 400	14 200
17	HK 1712	12.2	BK 1712	14.5	17	23	12	7 500	9 750	13 300
	HK 1718	19	-	-	17	23	18	9 500	10 600	10 000
18	HK 1812	13.1	BK 1812	14.9	18	24	12	7 700	10 350	12 350
	HK 1816	17.5	BK 1816	19.9	18	24	16	11 000	16 400	12 350
20	HK 2010	11.8	BK 2010	14	20	26	10	6 100	7 800	11 400
	HK 2012	14.1	BK 2012	16.7	20	26	12	8 200	11 500	11 400
	HK 2016	19.3	BK 2016	22.3	20	26	16	12 000	19 100	11 400
	HK 2020	24.1	BK 2020	27.1	20	26	20	14 900	24 700	11 400
	HK 2030 - ZW	34.7	BK 2030	37.4	20	26	30	20 700	38 000	11 400

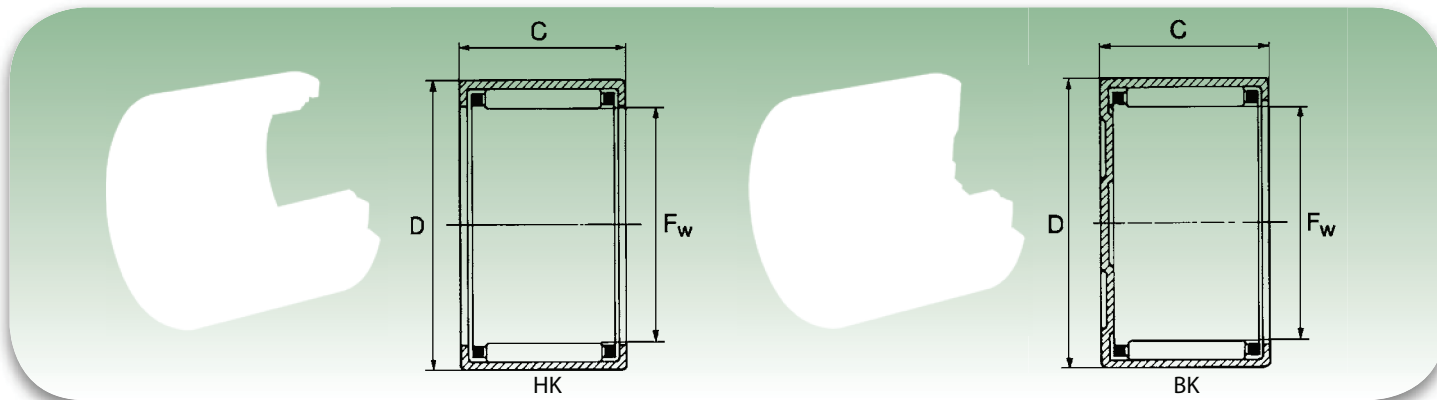

Diametro albero (mm) Shaft diameter (mm)	Sigla Designation				Dimensioni (mm) Dimensions (mm)			Coefficienti di carico (N) Basic Load Ratings (N)		Velocità limite Limiting Speed
	Astucci a rullini aperti Open end	Peso (g) Weight (g)	Astucci a rullini con fondello Closed end	Peso (g) Weight (g)	Fw	D	C	Dinamico C Dynamic C	Statico Co Static Co	Olio (N. giri max) Oil (max rpm)
22	HK 2210	12.3	-	-	22	28	10	7 100	9 950	10 450
	HK 2212	15	BK 2212	18.1	22	28	12	8 650	12 700	10 450
	HK 2216	20.9	BK 2216	24.3	22	28	16	12 700	21 000	10 450
	HK 2220	26.2	BK 2220	29.9	22	28	20	15 650	27 550	10 450
	HK 223218	21.9	-	-	22	32	18	19 800	34 000	9 000
25	HK 2512	20	BK 2512	23.2	25	32	12	10 450	14 450	9 500
	HK 2516	27.3	BK 2516	31	25	32	16	14 800	22 800	9 500
	HK 2520	34.1	BK 2520	38.7	25	32	20	18 900	31 350	9 500
	HK 2524	-	-	-	25	32	24	-	-	-
	HK 2526	44.8	BK 2526	49	25	32	26	24 200	42 750	9 500
	HK 2538 - ZW	64.7	BK 2538	69	25	32	38	32 300	62 700	9 500
28	HK 2816	30.1	BK 2816	34.1	28	35	16	15 600	25 200	8 550
	HK 2820	37.6	BK 2820	43	28	35	20	19 850	34 200	8 550
30	HK 3012	24	BK 3012	27.9	30	37	12	11 500	17 300	8 100
	HK 3016	32	BK 3016	37.1	30	37	16	16 350	27 550	8 100
	HK 3020	40.1	BK 3020	46.5	30	37	20	20 900	37 500	8 100
	HK 3022	42	-	-	30	37	22	24 500	45 000	8 100
	HK 3026	52.9	BK 3026	59.4	30	37	26	26 600	51 300	8 100
	HK 3038 - ZW	76.1	BK 3038	82.5	30	37	38	35 600	75 000	8 100
32	HK 3220	40.6	-	-	32	39	20	22 500	42 000	7 300
	HK 3224	50.7	-	-	32	39	24	25 500	52 000	7 300
35	HK 3512	27.7	BK 3512	32.9	35	42	12	12 450	20 250	7 150
	HK 3516	36.9	BK 3516	43.8	35	42	16	17 750	31 850	6 200
	HK 3520	46.1	BK 3520	54.8	35	42	20	22 600	43 700	6 150
40	HK 4012	31.1	BK 4012	38.2	40	47	12	13 300	23 100	6 200
	HK 4016	41.4	BK 4016	51	40	47	16	19 000	36 600	6 200
	HK 4020	51.8	BK 4020	62	40	47	20	24 250	49 400	6 200
45	HK 4512	34.8	BK 4512	45	45	52	12	14 150	26 150	5 700
	HK 4516	46.2	BK 4516	56	45	52	16	20 250	40 850	5 700
	HK 4520	56	BK 4520	72	45	52	20	25 650	56 050	5 700
	HK 4538	135	-	-	45	55	38	27 600	61 000	5 300
50	HK 5012	44.2	-	-	50	58	12	23 600	57 200	5 300
	HK 5020	72	BK 5020	87.3	50	58	20	29 450	59 850	4 750
	HK 5025	90.1	BK 5025	109	50	58	25	36 550	79 800	4 750
	HK 5038	140	-	-	50	58	38	27 770	63 100	4 600
55	HK 5520	78	BK 5520	93.8	55	63	20	29 950	63 650	4 450
	HK 5528	111	BK 5528	132	55	63	28	41 800	97 850	4 080
60	HK 6012	49.2	BK 6012	77	60	68	12	16 550	30 400	4 180
	HK 6020	86	BK 6020	105	60	68	20	31 800	71 250	4 180
	HK 6032	136	BK 6032	164	60	68	32	50 350	128 250	4 180

ZW = A due corone, con foro di lubrificazione. / Double rows, with lubrication hole.

In caso di lubrificazione a grasso, è ammesso un n° di giri pari al 60% dei valori riportati in tabella

For grease lubrication number of allowed revolution is 60% of value expressed in table (see specifications for different grease)