

FORCELLE CON FORO FILETTATO PER TIRANTI

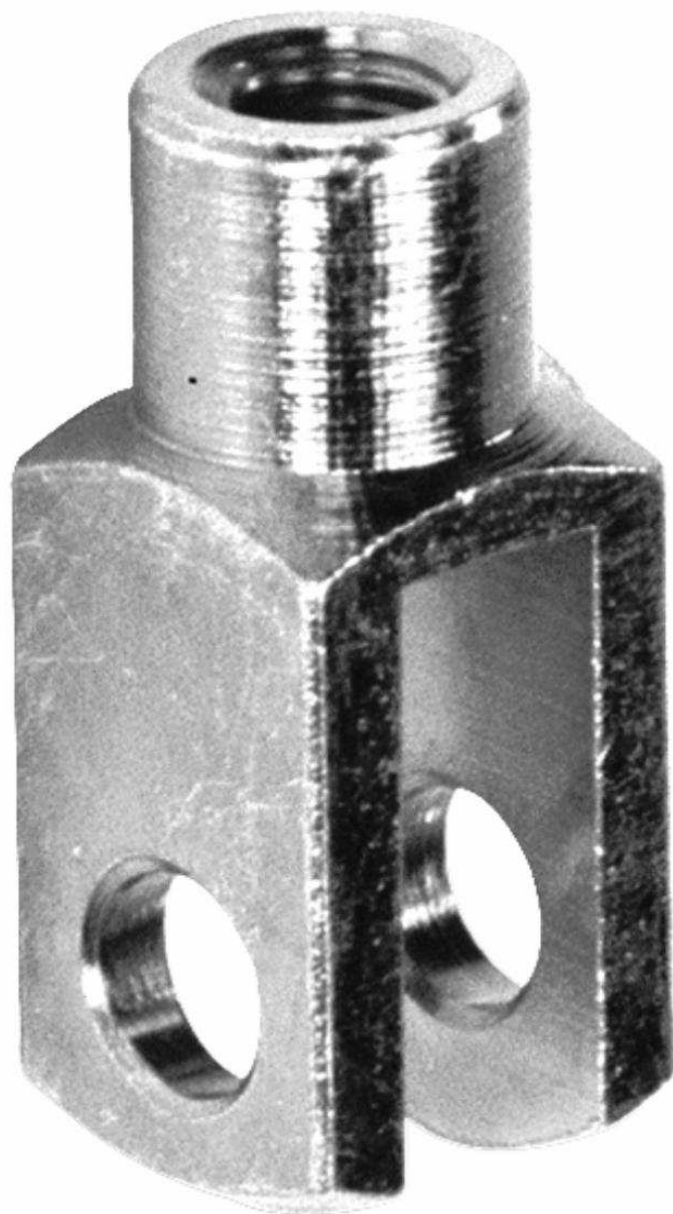

.

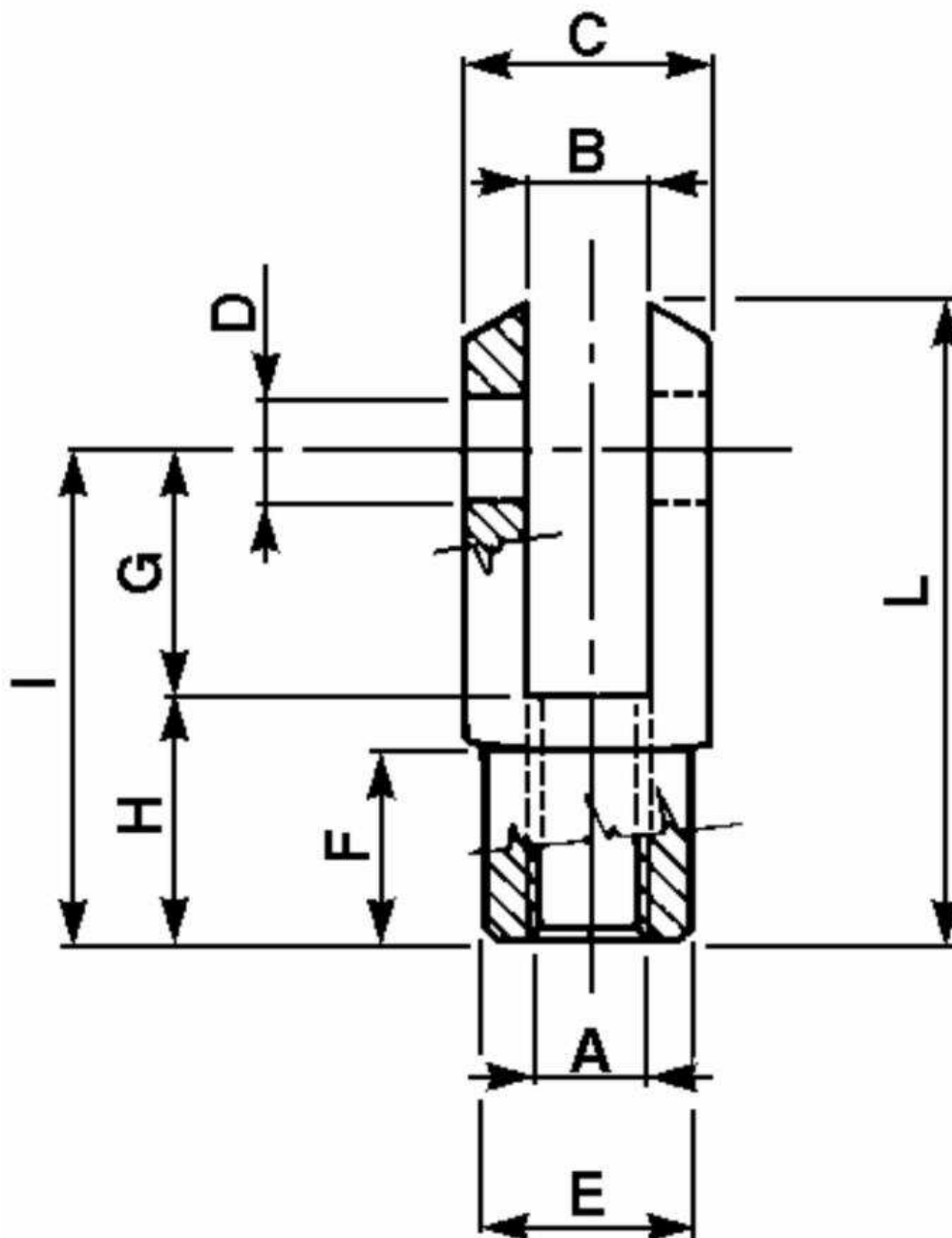

- [Caratteristiche tecniche](#)

Codice	Articolo	A mm	B mm	C mm	D mm	E mm	F mm	G mm	H mm	I mm	L mm
04510	M6	6.0	12.0	6.0	10.0	9.0	12.0	12.0	24.0	31.0	
04512	M8	8.0	16.0	8.0	14.0	12.0	16.0	16.0	32.0	42.0	
04514	M10	10.0	20.0	10.0	18.0	15.0	20.0	20.0	40.0	52.0	
04516	M12	12.0	24.0	12.0	20.0	18.0	24.0	24.0	48.0	62.0	
04518	M14	14.0	27.0	14.0	24.0	22.0	28.0	28.0	56.0	72.0	
04573	M16	16.0	32.0	16.0	26.0	24.0	32.0	32.0	64.0	83.0	
04506	M6	6.0	12.0	6.0	10.0	9.0	24.0	12.0	36.0	43.0	
04527	M8	8.0	16.0	8.0	14.0	12.0	32.0	16.0	48.0	58.0	
04528	M10	10.0	20.0	10.0	18.0	15.0	40.0	20.0	60.0	72.0	
12451	M12	12.0	24.0	12.0	20.0	18.0	48.0	24.0	72.0	86.0	
12452	M14	14.0	27.0	14.0	24.0	22.0	56.0	28.0	85.0	101.0	
12453	M16	16.0	32.0	16.0	26.0	24.0	64.0	32.0	96.0	115.0	