

art. 1/120/5



**BIDONE PER LA RACCOLTA DIFFERENZIATA**

Disponibile in 8 colori, con ruote da Ø 200 mm. Prodotto in polietilene ad alta densità di prima scelta (PE-HD), resistente agli agenti chimici, non attaccabile dai parassiti, non assorbe assolutamente i liquidi, è lavabile e sterilizzabile. Fornito smontato.

**BIN FOR DIFFERENTIATED REFUSE COLLECTION**

Available in 8 colours. It is supplied with wheels - Ø 200 mm. Made in high quality polythene (PE-HD), chemical agents and parasite resistant, liquid proof, washable and sterilizable.



Certificato  
Certified  
UNI EN 840



certified version

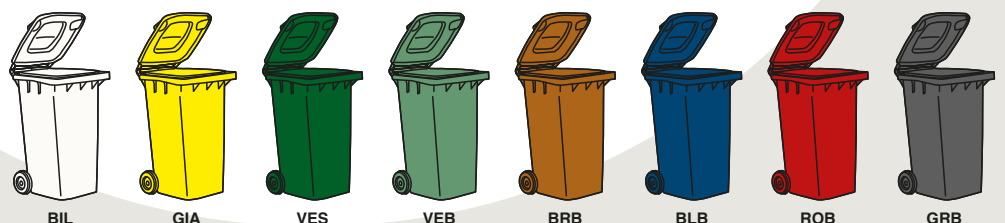

BIL

GIA

VES

VEB

BRB

BLB

ROB

GRB

COLORI - COLORS

CARATTERISTICHE TECNICHE BIDONE DA 120 Lt.  
TECNICAL CHARACTERISTICS OF 120 Lt. BIN

120 Litri	
A	930 mm
B	875 mm
C	485 mm
D	550 mm
E	480 mm
F	355 mm
G	480 mm
PESO/WEIGHT	9 Kg

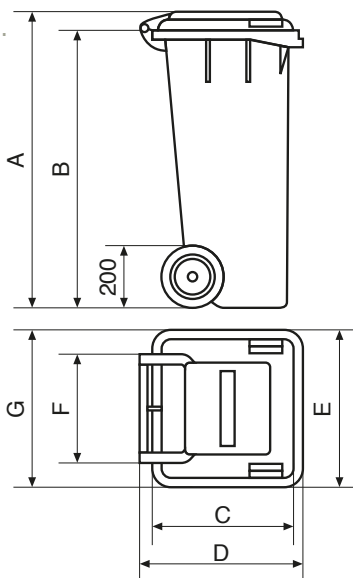

art. 1/120

Anello fermasacco per bidone 120 Lt.  
120 Lt. bin ring

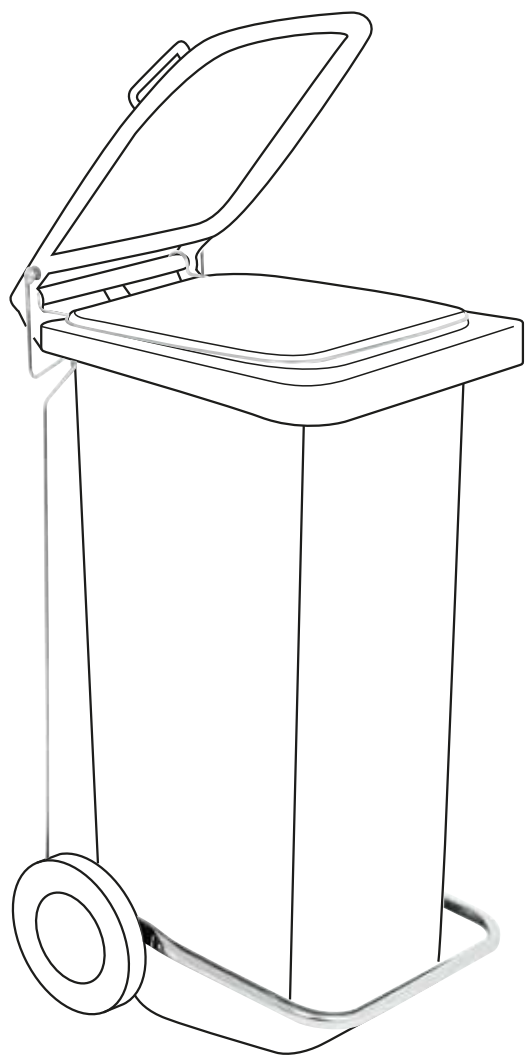

art. 1204

Kit pedale + anello per bidone 120 Lt.  
120 Lt. bin pedal and ring



esempio



art. 95/120

Sacchetti immondizia per bidone raccolta differenziata 120 Lt.  
Bin liners for 120 Lt. differentiated refuse collection bin